



Faculty of Computer Science – University “Goce Delcev” - Stip

Pneumatically actuated robot system for gait rehabilitation

Ass. Prof. Saso Koceski, PhD

E-mail: saso.koceski@ugd.edu.mk

This research is conducted in the Laboratory for Applied Mechanics and Robotics, at the University of L'Aquila, Italy (2005-2009)

Defining disability

- ❑ **Disability** = physical, mental, or psychological condition that limits a person's activities.
 - ❑ The World Health Organization (WHO) estimates that approximately 10% of the world's population (~ 700 million people), have a disability.
 - ❑ Worldwide statistics about disability show that:
 - ❑ in USA: 20% of the population have declare some kind of disability;
 - ❑ in UK: 18% of the population have some kind of disability;
 - ❑ in Australia: 20% of the population have declare some kind of disability.
 - ❑ in Japan: 5% of the population have some kind of disability ;
 - ❑ In Italy: 5% of the population (2.8 million) have some kind of disability;
 - ❑ Today one of the most commonly reported type of disability is the **locomotor disability**.
-

Defining disability

- ❑ **Locomotor disability** = person's inability to execute distinctive activities associated with moving both himself and objects, from place to place and such inability resulting from affliction of musculoskeletal and/or nervous system.

 - ❑ It can be consequence of diseases and impairments of:
 - ❑ cardiovascular,
 - ❑ pulmonary,
 - ❑ nervous,
 - ❑ sensory and musculoskeletal system

 - ❑ In this category entered the people with:
 - ❑ paraplegia,
 - ❑ quadriplegia,
 - ❑ multiple sclerosis,
 - ❑ muscular dystrophy,
 - ❑ spinal cord injury,
 - ❑ persons affected by stroke,
 - ❑ Parkinson disease etc.
-

Defining disability

- ❑ Worldwide statistics about locomotor disability:
 - ❑ in Australia: 6.8% of the population had a disability related to diseases of the musculoskeletal system, which is 34% of the persons with any kind of disability;
 - ❑ in USA: 700.000 - suffer from stroke each year; 10.000 - suffer from traumatic spinal cord injury, and over 250.000 are disabled by multiple sclerosis per year;
 - ❑ in England: overall, 12% of men and 14% of women reported having locomotor disability
 - ❑ in Italy: 1.800.000 people have declared some kind of locomotor disabilities.
-

Defining disability

- ❑ The number of people with disabilities is growing permanently as a result of several factors, such as:
 - ❑ population growth,
 - ❑ ageing
 - ❑ medical advances that preserve and prolong life.

 - ❑ These factors are creating considerable demands for health and rehabilitation services.

 - ❑ On the other hand, demand for rehabilitation services will increase the nation's health care financial burden (in every country), which continues to grow above the rate of inflation.

 - ❑ *For example:* in Australia in 2000-2001, 9.5% of total allocated health expenditure (\$4.7 billion) was spent on musculoskeletal diseases and 9.9% on diseases of the nervous system.
-

Rehabilitation

- ❑ Rehabilitation is very important part of the therapy plan for patients with locomotor dysfunctions in the lower extremities.
- ❑ During the rehabilitation process the human motor system should re-learn the correct spatio-temporal patterns of muscle activation to achieve a desired limb trajectory (**gait rehabilitation**).
- ❑ The goal of gait rehabilitation is to:
 - ❑ to re-train the nervous system,
 - ❑ to re-build muscle strength,
 - ❑ to improve balance and
 - ❑ to re-train kinematics in order to reduce the stresses applied to bones and muscles.
- ❑ It is clinically proved [1] that intensive and repetitive training and exercise may enhance motor recovery or even restore motor function in people suffering from neurological injuries, such as spinal cord injury (SCI), stroke, multiple sclerosis (MS), Parkinson disease (PD) and traumatic brain injury (TBI).

Gait rehabilitation modalities

- ❑ Historically, three different modalities of gait rehabilitation can be individuated:
 - ❑ conventional (manual) gait rehabilitation
 - ❑ partial bodyweight support (PBWS) treadmill gait rehabilitation with manual assistance
 - ❑ robot-assisted gait rehabilitation
-

Conventional manual therapy

- ❑ Specific exercises for strengthening and practicing of one single movement at time.
- ❑ Individual mixture of methods and exercises from the therapists' toolbox, determined by:
 - ❑ the possibilities and character of the patient,
 - ❑ the preferences and experience of the therapist.
- ❑ **Parallel bars** allow patients to support themselves using their upper body strength while actively walking
- ❑ Gradually put more and more weight on their legs as they recover their ability to walk.



Manually assisted partial bodyweight support (PBWS) treadmill gait rehabilitation

BWS provides proper upright posture, balance and safety during treadmill walking.



removes a controllable portion of the weight from the legs, allowing free movement of the patients' arms and legs

Proper coordination is further assisted the manual placement of the feet by 2-3 therapists

The movement is provided by a constant speed moving treadmill

As patients progress, the BWS can be gradually decreased, challenging the patient to assert more postural control and balance

Manually assisted partial bodyweight support (PBWS) treadmill gait rehabilitation

Drawbacks:

- ❑ Exhaustive for therapists
 - ❑ Training sessions tend to be short and may limit the full potential of the treatment
 - ❑ Lack of repeatability and precision
 - ❑ Lack of objective measures of patient performance and progress
-

Robot systems for gait training

Locomat (commercially available):

It is a motor driven exoskeleton device that employs a BWS suspension system and treadmill.



The legs of a patient are strapped into an adjustable aluminum frame that provides powered assistance at the hip and knee while the patient steps on a treadmill.

A therapist can monitor the system and provide assistance if necessary.

Robot systems for gait training

Gait Trainer (commercially available):

- ❑ A single degree-of-freedom powered machine that drives the feet through a gait-driven trajectory.
- ❑ Gait Trainer use a servo-controlled motor that sense the patients' effort, and keeps the rotation speed constant.
- ❑ Gait Trainer does not directly control the hip and knee joints, so a manual assistance of one physiotherapist is needed to assist their proper movements.
- ❑ Gait Trainer is not suitable for non-ambulatory people with weak muscles but only for those that have some degree of control of the hip/knee joints.



Robot systems for gait training

HapticWalker (still in research phase):

- ❑ Programmable footplate machine, with permanent foot machine contact.
- ❑ Foot movement in sagittal plane is performed by linear direct drive motors.
- ❑ The system is able to simulate not only 'smooth' trajectories like walking on plane floor, stepping stairs up/down, walking on rough ground or even stumbling.
- ❑ The interaction only takes place at the foot sole, so that typical poor joint stability of stroke patients cannot be controlled.



Robot system for gait training

Lower limb rehabilitation exoskeleton device developed at the University of L'Aquila, Italy.

General requirements:

- ❑ Ergonomic structure
 - ❑ Adjustable structure (patients tall 165-190cm)
 - ❑ Anthropomorphic structure
 - ❑ Light and resistant structure
 - ❑ **LOW COST SYSTEM**
-

Robot system for gait training

Lower limb rehabilitation exoskeleton device developed at the University of L'Aquila, Italy.

Ergonomic structure - 10 degrees of freedom all rotational: two on the pelvis level, two for the hips, two for the knees, and four for the ankles;

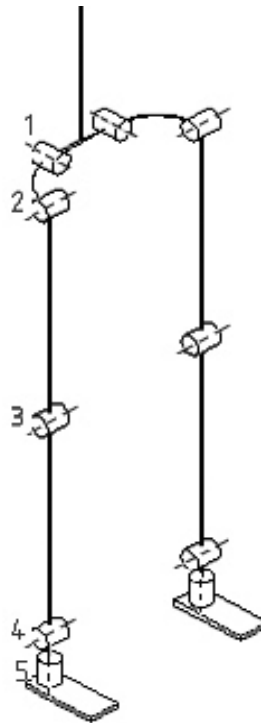

no additional DOF or motion ranges are needed to follow the patient motion

Robot system for gait training

Lower limb rehabilitation exoskeleton device developed at the University of L'Aquila, Italy.

- The inferior limbs of the exoskeleton are made up of three links corresponding to the thighbone, the shinbone and the foot.

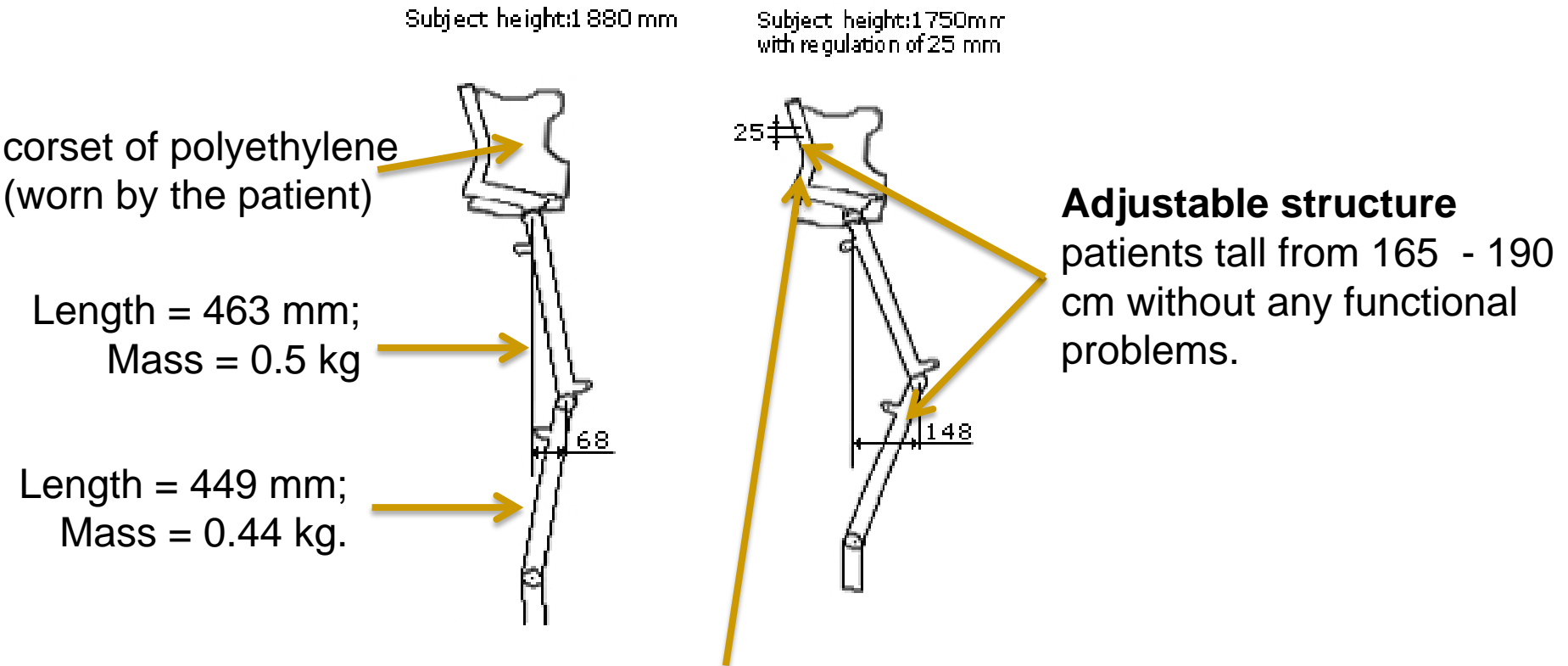

Adjustable connection between the corset and the horizontal rod at the pelvis level

Robot system for gait training

Lower limb rehabilitation exoskeleton device developed at the University of L'Aquila, Italy.

- **Anthropomorphic structure** – follows the natural shape of the human's lower limbs, the orientation and position of the human leg segments

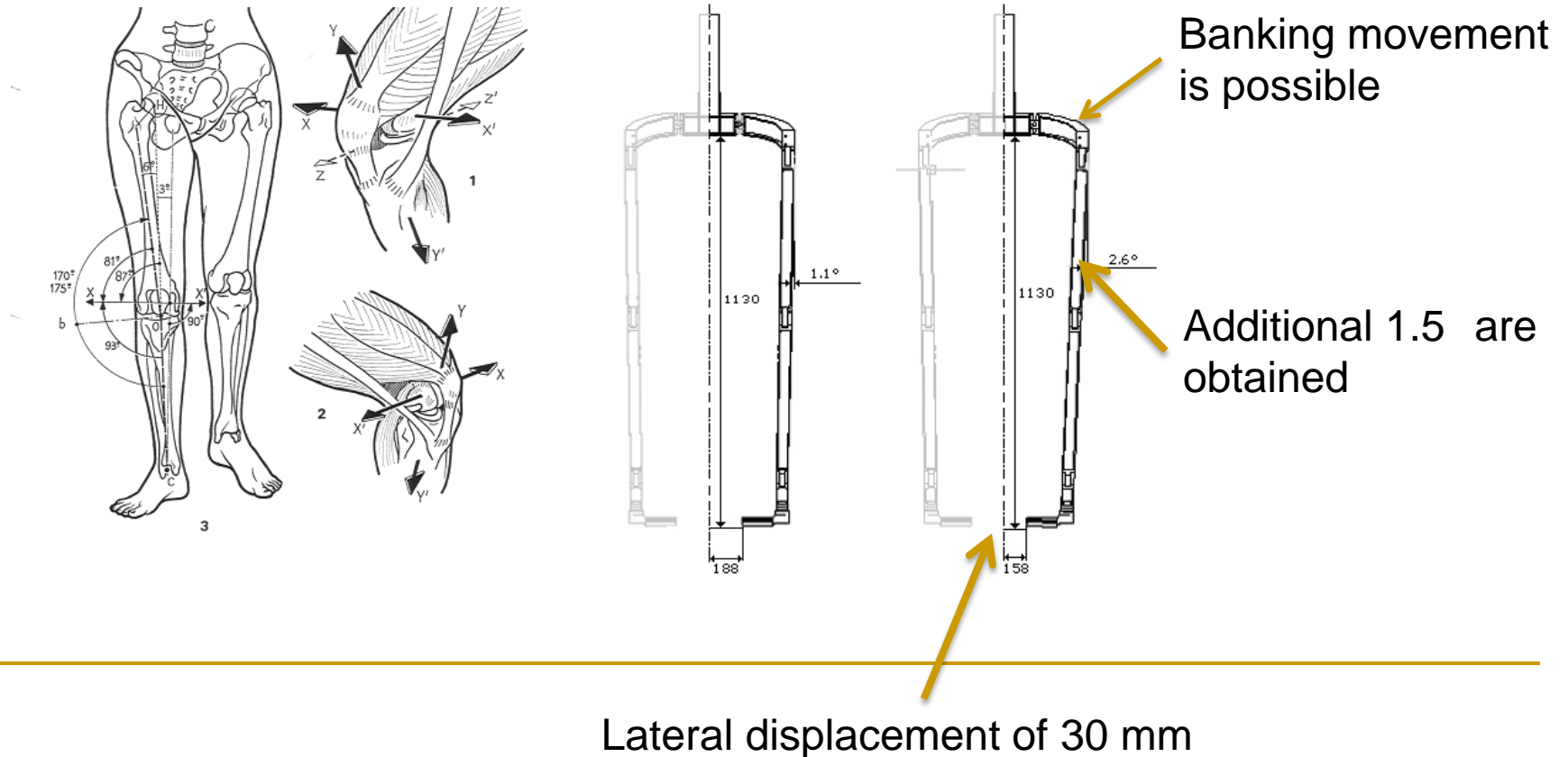

Robot system for gait training

Lower limb rehabilitation exoskeleton device developed at the University of L'Aquila, Italy.

❑ Follows natural movements of the COG

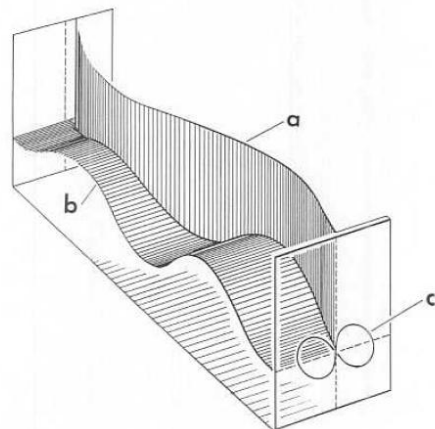
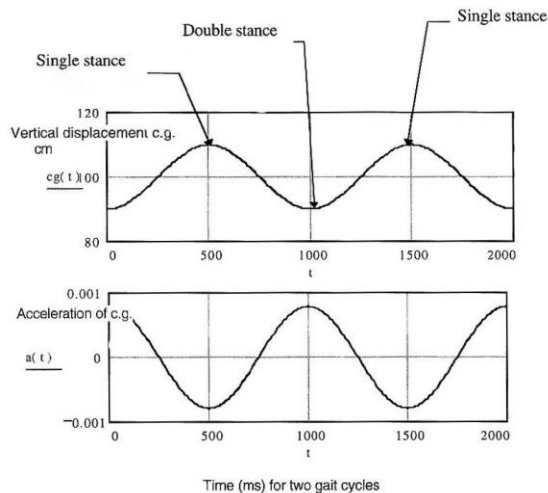

Robot system for gait training

Lower limb rehabilitation exoskeleton device developed at the University of L'Aquila, Italy.

- ❑ **Safety structure** - The exoskeleton structure also has to guarantee the safety of the patient
- ❑ Joints motions directly correspond with that of a patient
- ❑ Mechanical safety limits (physical stops), placed on extreme ends of the allowed range of motion of each DOF
- ❑ **Light and resistant structure** - Aluminum 6082 T6 ensures a light weight and a good resistance

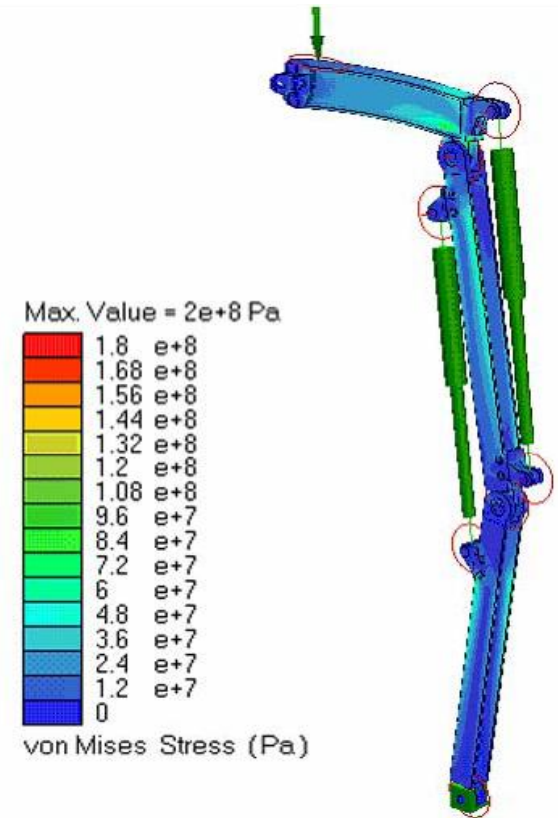

Mechanical resistance calculated in Visual Nastran using Finite Element Analysis (FEA)

Robot system for gait training

❑ Choosing the actuators

❑ Pneumatic systems are used to meet the need of:

❑ lower cost,

❑ high power-to-weight ratio,

❑ long duration,

❑ ease of maintenance,

❑ cleanliness.

❑ Moreover, the choice of adopting the pneumatic actuators to actuate the joints is biologically inspired.

❑ They provide linear movements, and are actuated in both directions, so the articulation structures do not require the typical antagonistic scheme proper of the biological joints.

Robot system for gait training

- ❑ Choosing the actuators – pneumatic muscles or cylinders?



Lightweight

The force is not only dependent on pressure but also on their state of inflation

Delay between the movement control signal and the effective muscle action



Robot system for gait training

Lower limb rehabilitation exoskeleton device developed at the University of L'Aquila, Italy.

- Rehabilitation system is actuated by 4 pneumatic actuators, two for each inferior limb of the exoskeleton

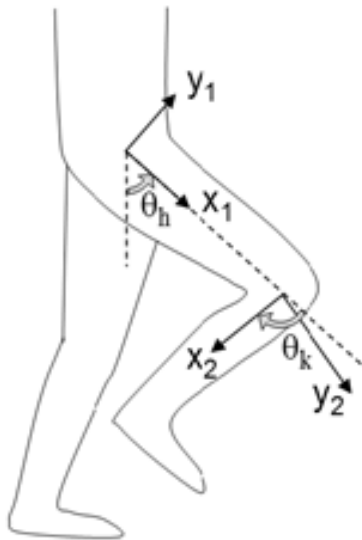

Rod stroke 180 mm
Bore diameter 32 mm

Rod stroke 160 mm
Bore diameter 32 mm

CM2 C32F-180,
CM2 C32F-160

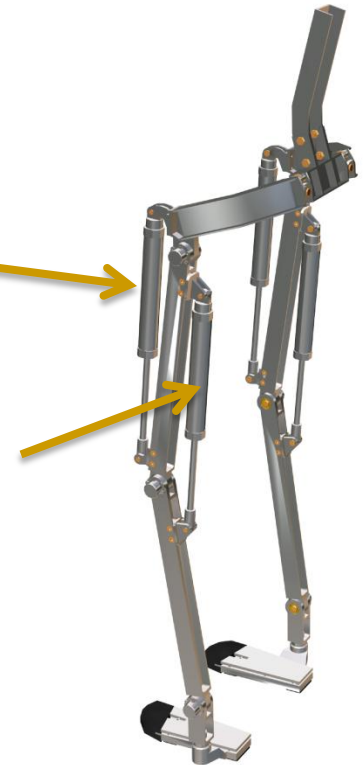

$\ominus_h =$ from -20 to 10

$\ominus_k =$ from 10 to 70

Robot system for gait training

Lower limb rehabilitation exoskeleton device developed at the University of L'Aquila, Italy.

- ❑ Actuators are capable to provide force of about 750 N under $P = 0.9$ MPa (external compressor)
 - ❑ Each cylinder's piston is controlled by two pressure proportional valves (SMC-ITV 1051-312CS3-Q), connected to both cylinder chambers
 - ❑ **Sensors:**
 - ❑ Rotational potentiometers for hip, knee and ankle joint angles
 - ❑ Single axis force sensors
-

Robot system for gait training

Modelling of the mechanical (sub)system

- Valve model involves two aspects:
 - the dynamics of the valve spool and
 - the mass flow through the valve's variable orifice.

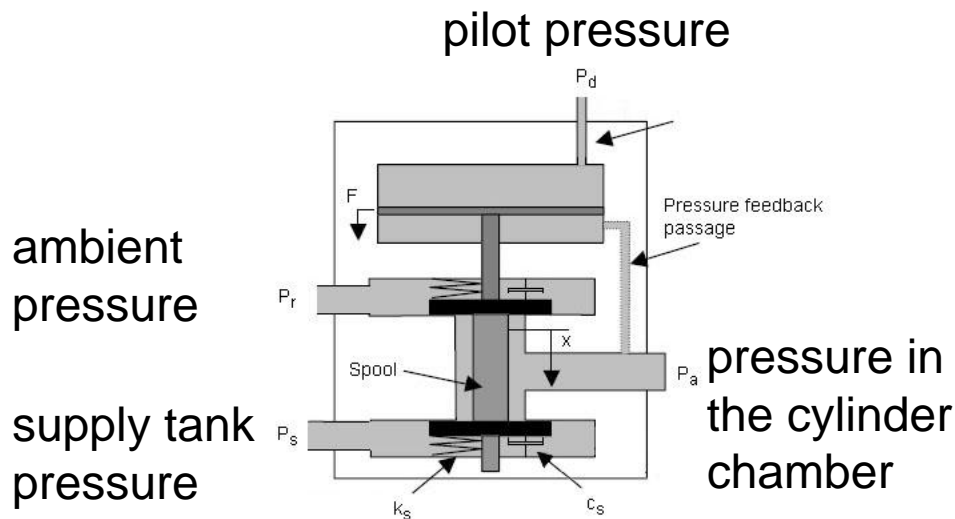

$k_s = 1500 \text{ N/m}$ is the poppet stiffness

$c_s = 13 \text{ N/ms}^{-1}$ is the poppet damping

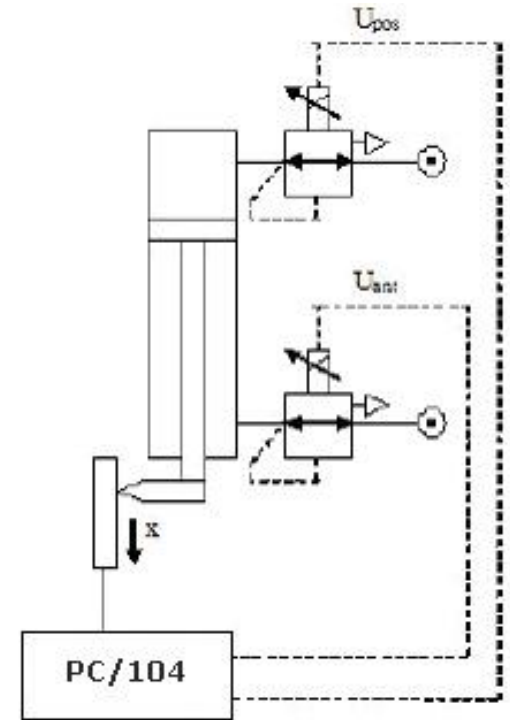

Robot system for gait training

Modelling of the mechanical (sub)system

- The force F_s that moves the spool, which in turn operates the poppet valve

$$(P_d - P_a)S = F_s$$

- P_d responds to voltage input V_i (due to the control circuitry) as:

$$P_d = k_v V_i \quad k_v = 89500 \text{ Pa/V is the valve related coefficient}$$

- Neglecting the inertia of the spool, the force applied to poppets is given by:

$$F_p = c_s \dot{x}_s + k_s x_s$$

- This model allows independent movement of both poppets
 - if $(P_d - P_a) > 0$ positive flow towards the cylinder's chamber will be created
 - if $(P_d - P_a) < 0$ negative flow that will exhaust the cylinder's chamber, will be created

Robot system for gait training

Modelling of the mechanical (sub)system

- The mass flow rate of the compressible gas through a valve orifice with area a is given by:

$$\dot{m}_a = \begin{cases} C_q a C_1 \frac{P_u}{\sqrt{T}} & \text{if } \frac{P_d}{P_u} \leq P_{cr} \text{ (choked flow)} \\ C_q a C_2 \frac{P_u}{\sqrt{T}} \left(\frac{P_d}{P_u}\right)^{1/\gamma} \sqrt{1 - \left(\frac{P_d}{P_u}\right)^{(\gamma-1)/\gamma}} & \text{if } \frac{P_d}{P_u} > P_{cr} \text{ (unchoked flow)} \end{cases}$$
$$C_1 = \sqrt{\frac{\gamma}{R} \left(\frac{2}{\gamma+1}\right)^{\frac{\gamma+1}{\gamma-1}}} \quad C_2 = \sqrt{\frac{2\gamma}{R(\gamma-1)}}$$
$$P_{cr} = \left(\frac{2}{\gamma+1}\right)^{\frac{\gamma}{\gamma-1}}$$

- C_q is a non-dimensional, discharge coefficient, P_u is the upstream pressure, P_d is the downstream pressure, R is the gas constant
- For air ($\gamma = 1.4$; $R = 287 \text{ Jkg}^{-1}\text{K}^{-1}$) $\Rightarrow C_1 = 0.040418$, $C_2 = 0.156174$, and $P_{cr} = 0.528$
- The orifice area a , is given as: $a = k_c x_p$

$k_c = 3\text{e-}2\text{m}$ poppet circumference and x_p is poppet displacement

Robot system for gait training

Modelling of the mechanical (sub)system

- The total mass flow rate into the chamber is the sum of the mass flow rates from both poppets

$$\dot{m}_a = \frac{C_q k_c}{\sqrt{T}} \left\{ P_s x_{p1} \left(\frac{P_a}{P_s} \right)^{1/\gamma} \sqrt{1 - \left(\frac{P_a}{P_s} \right)^{(\gamma-1)/\gamma}} - P_a x_{p2} \left(\frac{P_r}{P_a} \right)^{1/\gamma} \sqrt{1 - \left(\frac{P_r}{P_a} \right)^{(\gamma-1)/\gamma}} \right\}$$

- The equation for energy conservation for a controlled volume of gas (from the first law of thermodynamics):

$$\dot{Q} - \dot{W} + \sum_i (h + e_k + e_p) \dot{m}_i - \sum_o (h + e_k + e_p) \dot{m}_o = \frac{d}{dt} \int_v e \rho dv$$

- \dot{Q} - the rate of heat transfer across the cylinder walls,

- \dot{W} - the rate of change in the work on the moving piston,

- $\sum_i (h + e_k + e_p) \dot{m}_i$ - the total energy of the gas entering into a chamber,

- $\sum_o (h + e_k + e_p) \dot{m}_o$ - the total energy of the gas leaving a chamber,

-
- $\frac{d}{dt} \int_v e \rho dv$ - the change of internal energy

Robot system for gait training

Modelling of the mechanical (sub)system

□ Assuming that:

□ the rate of change in kinetic and potential energies are negligible in comparison to the rate of change of internal energy of the controlled volume

□ the process is adiabatic, i.e. $\dot{Q} = 0$

□ that $T_i = T_o = T_s$

$$\dot{p} = \frac{RT_o}{V} + \left(\gamma \dot{m}_i \frac{T_i}{T_o} - \dot{m}_o \right) - \gamma \frac{p \dot{V}}{V}$$

□ Putting $m = m_i - m_o \quad \Rightarrow \quad \dot{p} = \frac{RT_o}{V} \gamma \dot{m} - \gamma \frac{p \dot{V}}{V}$

Robot system for gait training

Modelling of the mechanical (sub)system

- Due to the asymmetric nature of the cylinder chambers

$$V_a = V_{da} + A_a x$$

$$V_b = V_{db} + A_b (L - x)$$

- The rate of change in pressure in the cylinder chambers

$$\dot{p}_a = \left(\dot{m}_a - \frac{p_a A_a}{RT_s} \dot{x} \right) \frac{\gamma RT_s}{(V_{da} + x A_a)}$$

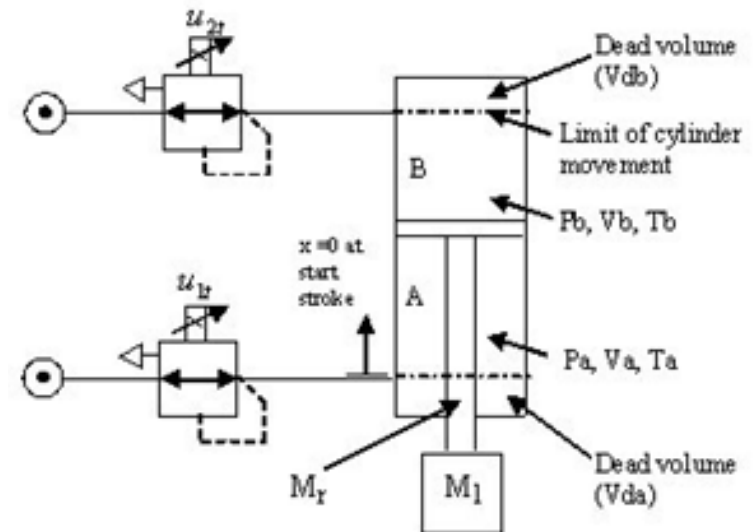

Robot system for gait training

Modelling of the mechanical (sub)system

- The motion's equation is given by

$$M \ddot{x} = P_a A_a - P_b A_b - D \dot{x} - Mg$$

- where $M = M_r + M_l + M_p$ is the sum of the mass:
 - of the cylinder's rod,
 - of the external load and
 - of the piston
- D is the viscous damping coefficient, that's mean it takes in count the friction effect in approximate manner.

Robot system for gait training

Modelling of the mechanical (sub)system

Model validation

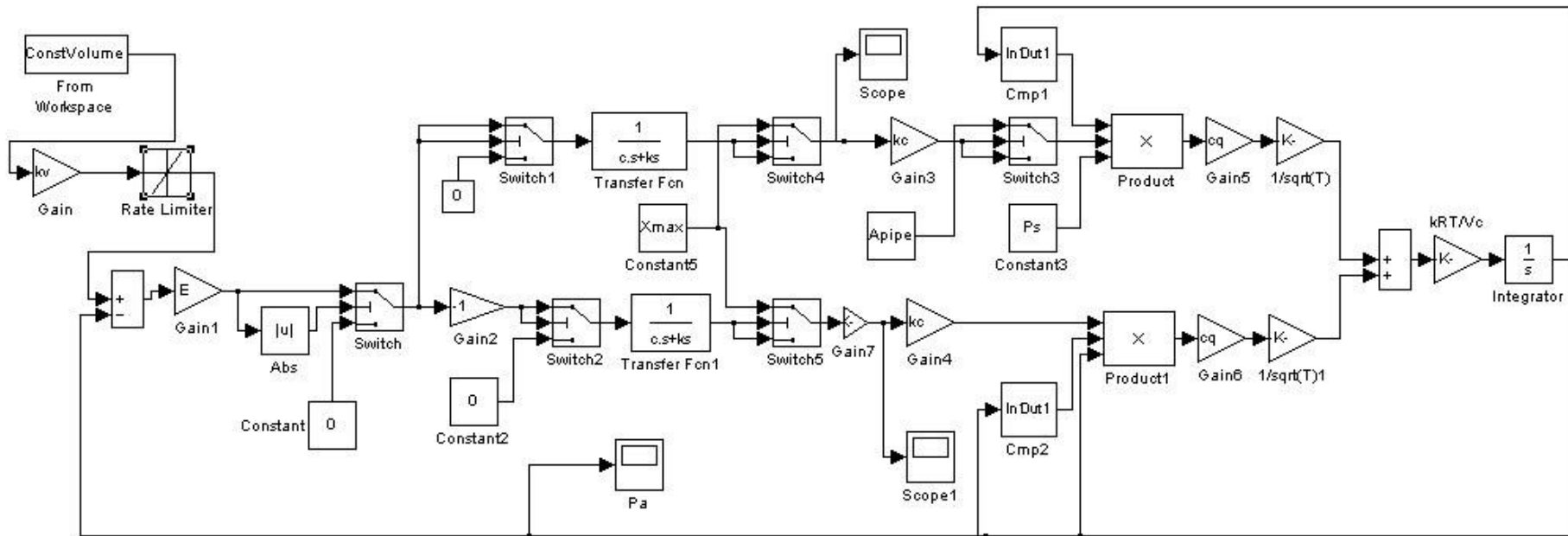

Robot system for gait training

Modelling of the mechanical (sub)system

□ Model validation

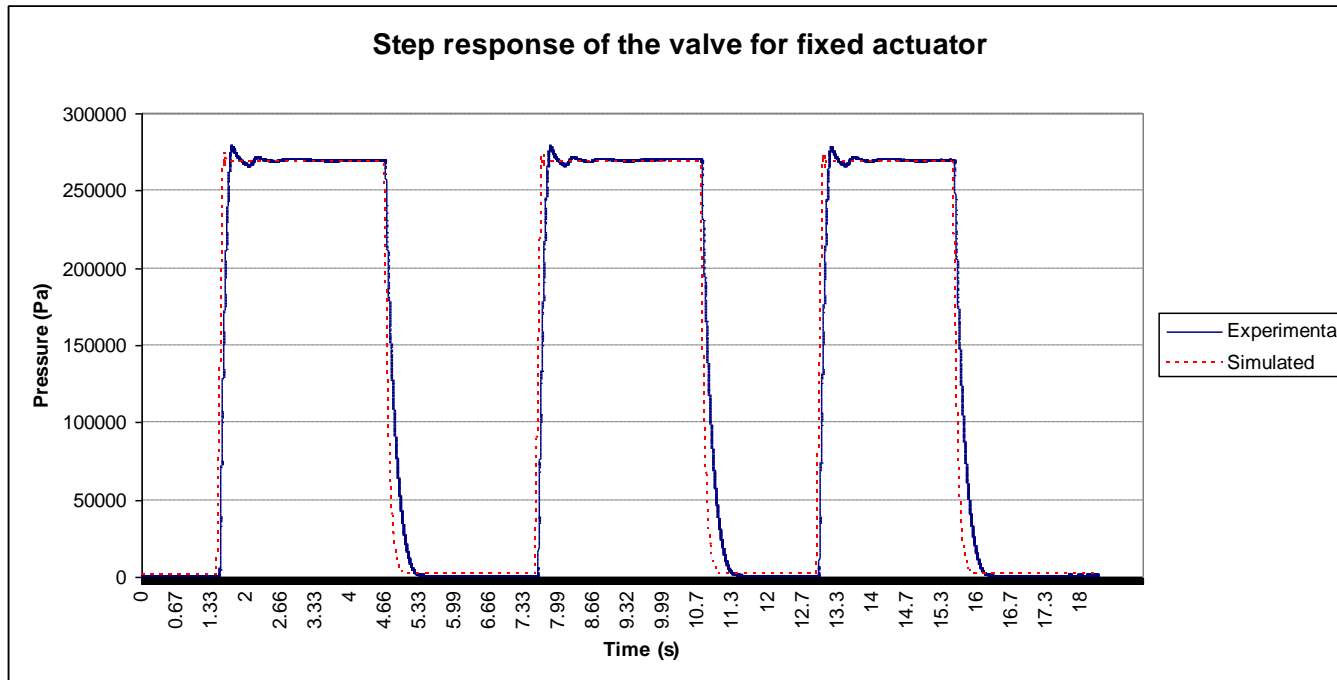

Rising time $T_{10/90}$ (s): 0.130 (simulated)

Rising time $T_{10/90}$ (s): 0.139 (experimental)

Robot system for gait training

Lower limb rehabilitation exoskeleton device developed at the University of L'Aquila, Italy.

- Rehabilitation system supports patients with mass $\leq 90\text{kg}$

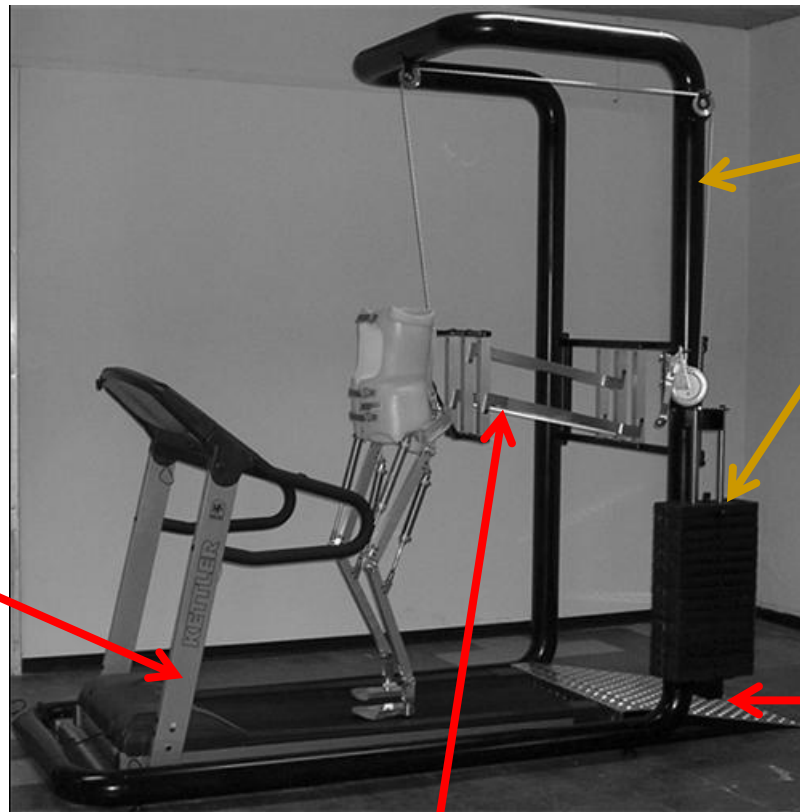

Chassis with weight balance

Patients in a wheelchair can be escorted on a ramp onto the treadmill

space guide mechanism allows vertical and horizontal movements

Treadmill speed synchronized with patients legs

Human movement analysis

- ❑ The aim of the controller :
- ❑ **To enable efficient trajectory control which will guide a patient according to natural, repetitive movements**
- ❑ Single camera system for analyzing the human walking was used



- ❑ Optical axis perpendicular in respect of the sagittal plane of the gait motion

Human movement analysis

- ❑ Recording methodology:
- ❑ To reduce the perspective effects (camera treadmill distance $L_{ct}=13m$)
- ❑ Use the central part of the objective to avoid the distortion introduced from the peripheral zones
- ❑ Use only the optical zoom
- ❑ Place an object with known dimension (grid) inside the filming zone
- ❑ Place the markers that corresponds to the hip, knee and ankle joints
- ❑ place the focus of the camera in the middle of the hip and ankle line:

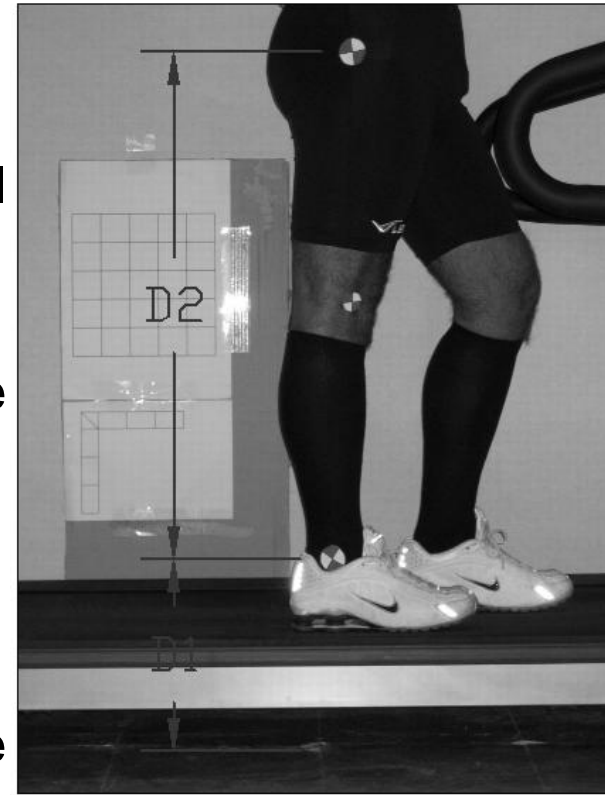

video resolution: 25 frame/s

$$D = D_1 + \frac{D_2}{2}$$

Inverse kinematics

- Converting the pixel values into distances using conversion factor obtained from the grid

- Along X:

$$1 \text{ pixel} = \frac{150}{97} = 1.5464 \text{ mm}$$

- Along Y:

$$1 \text{ pixel} = \frac{150}{88} = 1.7045 \text{ mm}$$

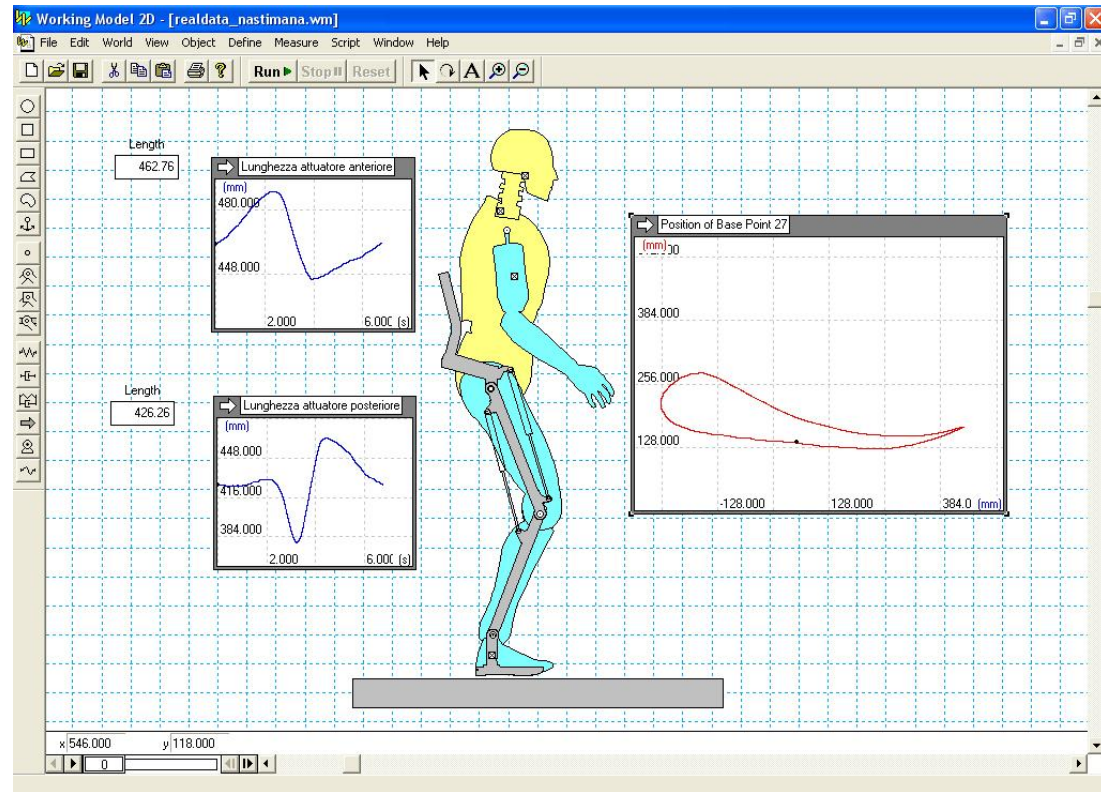
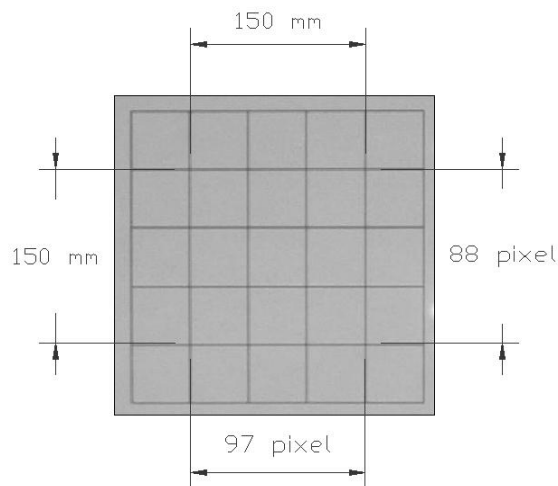

Control architecture

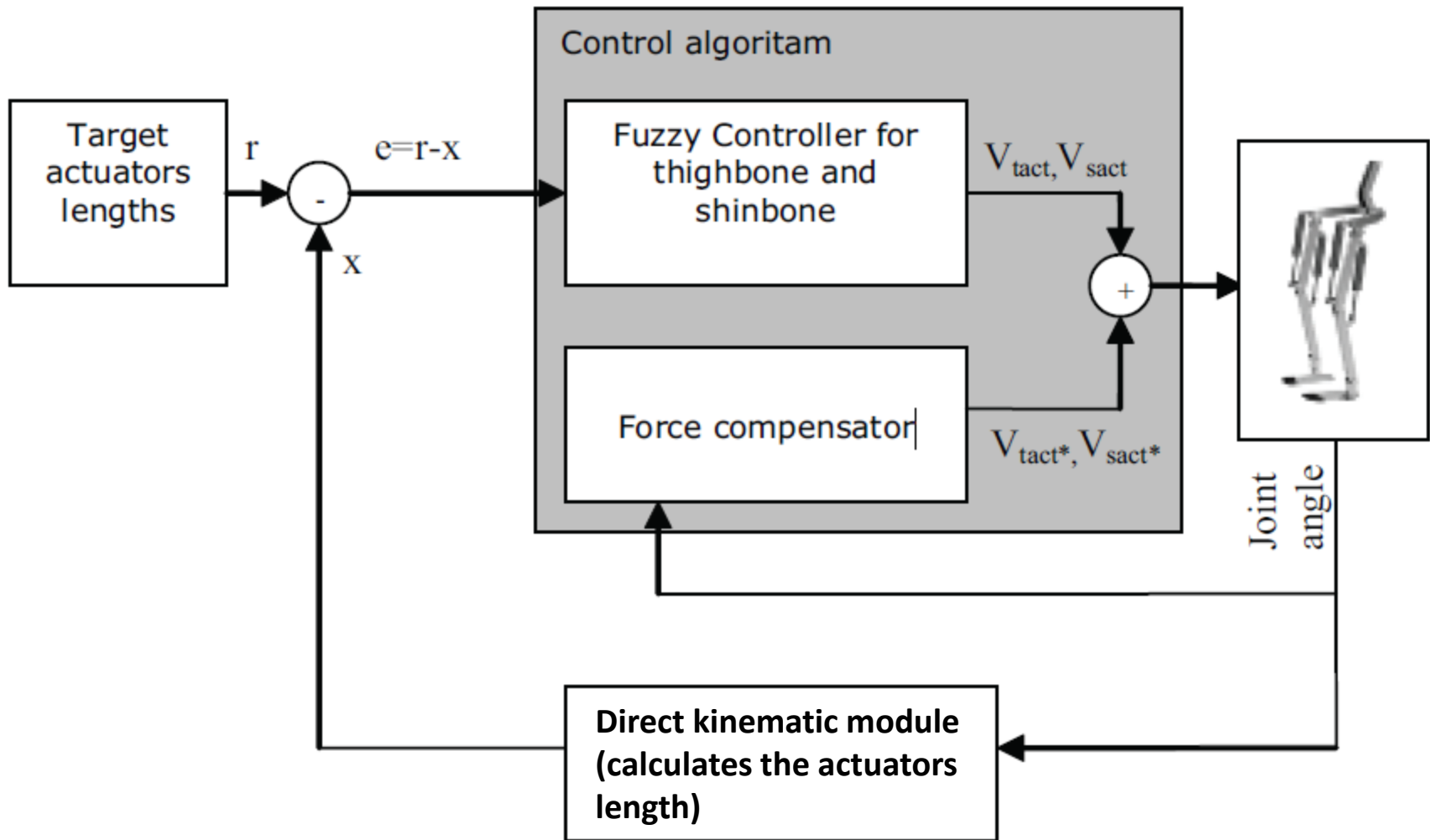

Fuzzy PD controller

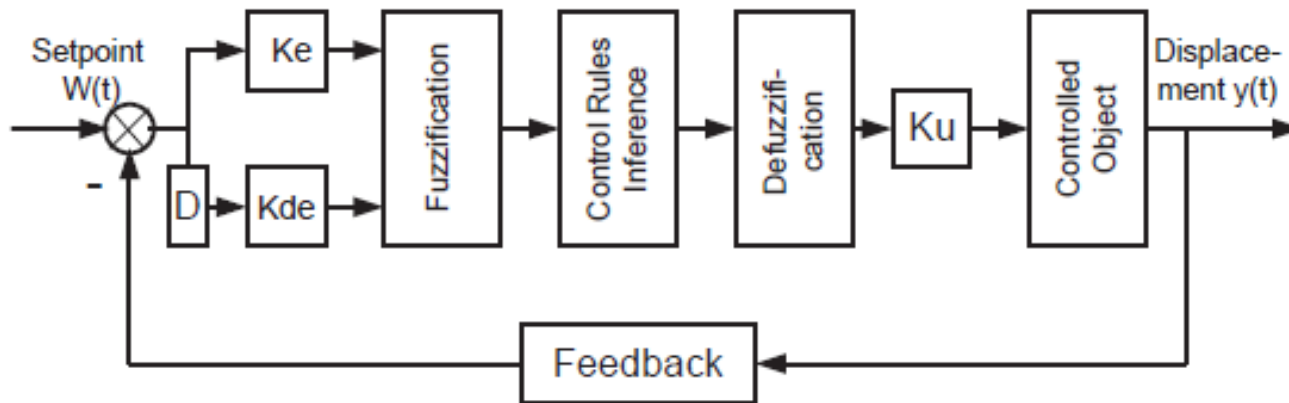

$K_e; K_{De}; K_u$ scaling factors for normalized input and output signals

$$\hat{e}(kT) = e(kT)K_e = (w(kT) - y(kT))K_e,$$

$$\Delta\hat{e}(kT) = \frac{e(kT) - e((k-1)T)}{T}K_{\Delta e},$$

$$\hat{u}(kT) = u(kT)/K_u.$$

Input linguistic variables E; ΔE

Output linguistic variables U1; U2

Defined in the domain of $D_N = [-1, 1]$

Fuzzy PD controller

Membership functions of normalized fuzzy input variables E and ΔE :

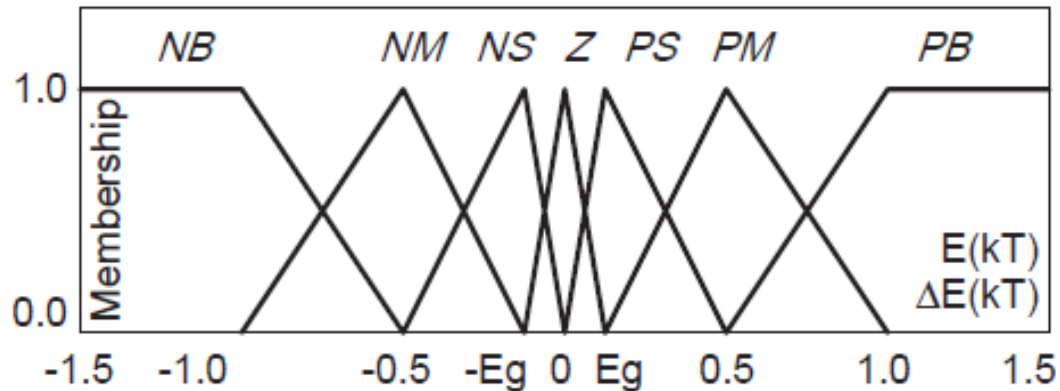

Rule matrix for fuzzy controller

Error E	Error change rate ΔE						
	<i>NB</i>	<i>NM</i>	<i>NS</i>	<i>Z</i>	<i>PS</i>	<i>PM</i>	<i>PB</i>
<i>NB</i>	<i>NB</i>	<i>NB</i>	<i>NB</i>	<i>NB</i>	<i>NM</i>	<i>NS</i>	<i>NVS</i>
<i>NM</i>	<i>NM</i>	<i>NM</i>	<i>NM</i>	<i>NM</i>	<i>NS</i>	<i>NVS</i>	<i>Z</i>
<i>NS</i>	<i>NS</i>	<i>NS</i>	<i>NVS</i>	<i>NVS</i>	<i>NVS</i>	<i>Z</i>	<i>PVS</i>
<i>Z</i>	<i>NS</i>	<i>NVS</i>	<i>Z</i>	<i>Z</i>	<i>Z</i>	<i>PVS</i>	<i>PS</i>
<i>PS</i>	<i>NVS</i>	<i>Z</i>	<i>PVS</i>	<i>PVS</i>	<i>PVS</i>	<i>PS</i>	<i>PS</i>
<i>PM</i>	<i>Z</i>	<i>PVS</i>	<i>PS</i>	<i>PM</i>	<i>PM</i>	<i>PM</i>	<i>PM</i>
<i>PB</i>	<i>PVS</i>	<i>PS</i>	<i>PM</i>	<i>PB</i>	<i>PB</i>	<i>PB</i>	<i>PB</i>

$IF(E \text{ IS } X_i) \text{ AND } (\Delta E \text{ IS } Y_j) \text{ THEN } (U \text{ IS } U_k)$

Fuzzy PD controller

MAX-PRODUCT - fuzzy inference method is used to determine the overall membership function of the control action output

$$\mu_{res,n}(\mu_{X_i}, \mu_{Y_j}) = \max\{\mu_{X_i}(\hat{e}(kT)) \cdot \mu_{Y_j}(\Delta\hat{e}(kT))\}.$$

Weight center method is selected for defuzzification

$$\hat{u} = \frac{\sum_{k=1}^{k=9} \sum_{n=1}^{n=49} \mu_{res,n}(\mu_{X_i}, \mu_{Y_j}) m_k}{\sum_{n=1}^{n=49} \mu_{res,n}(\mu_{X_i}, \mu_{Y_j})}.$$

the membership functions of output fuzzy variables U are in form of Singleton

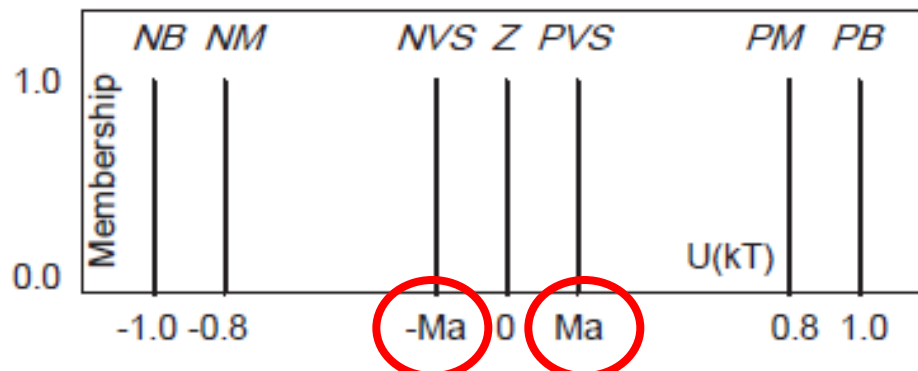

Adaptive controller parameter for friction compensation and accurate position control

Fuzzy PD controller

Transform characteristic curve of adaptive fuzzy controller parameter M_a

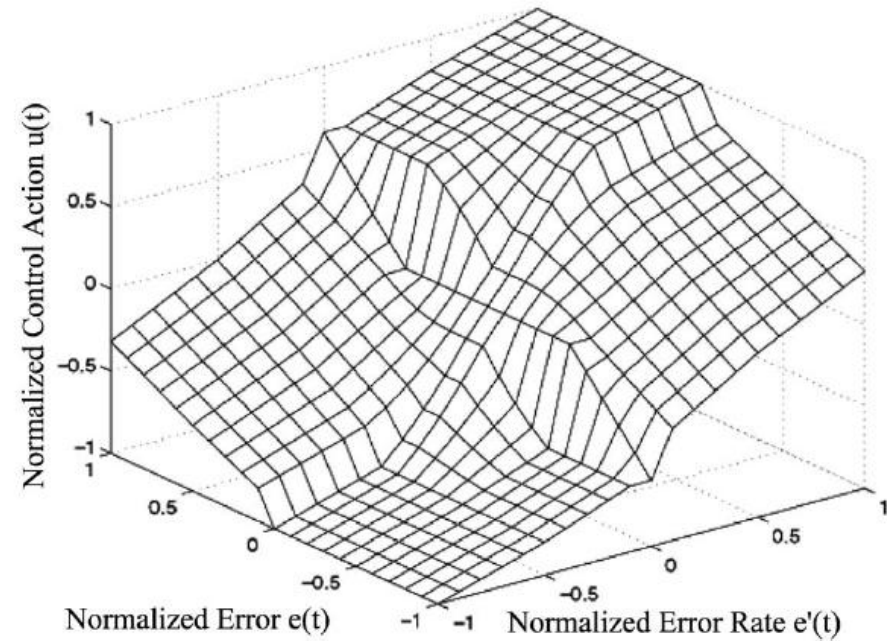
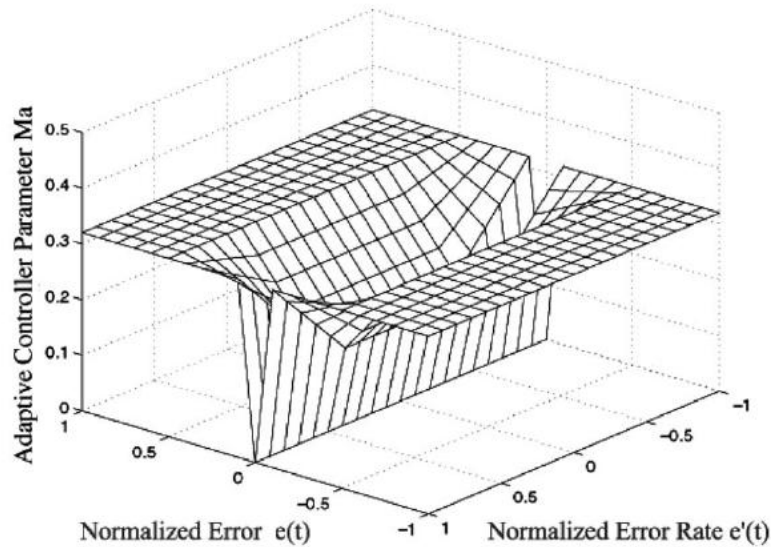

Transform characteristic curve of Fuzzy-PD controller

Kinematical behavior and joint forces

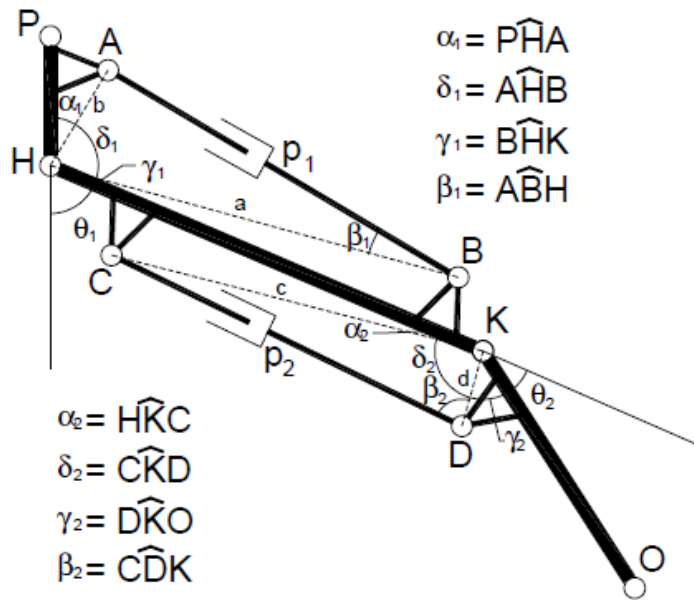

$$\begin{cases} \delta_2 = \pi - \theta_2 - \gamma_2 - \alpha_2 \\ p_2 = \sqrt{c^2 + d^2 - 2cd \cos \delta_2} \\ \beta_2 = \sin^{-1} \left(\frac{c \sin \delta_2}{p_2} \right) \end{cases}$$

$$F_{Sact} = \frac{M_S g L_{KG_S} \sin(\theta_1 - \theta_2)}{d \sin(\beta_2)}$$

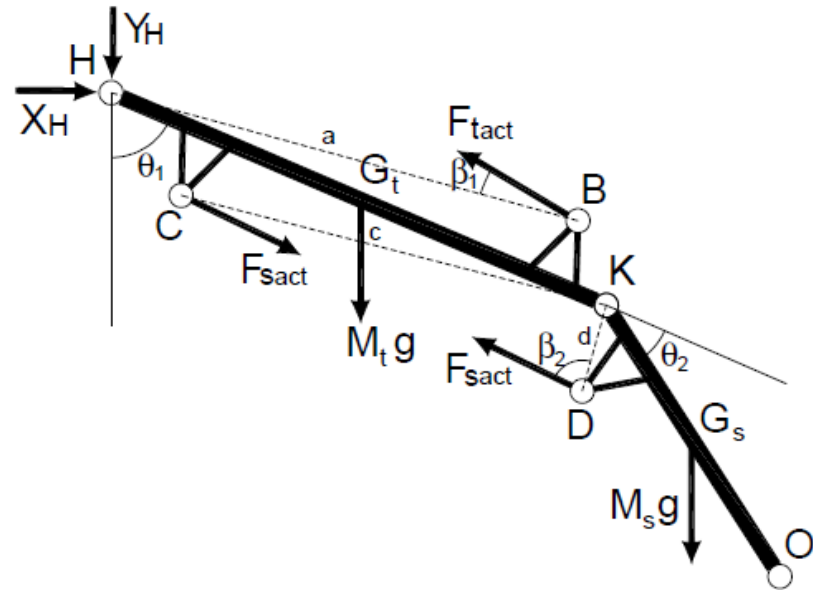

$$\begin{cases} \delta_1 = \pi - \theta_1 - \gamma_1 - \alpha_1 \\ p_1 = \sqrt{a^2 + b^2 - 2ab \cos \delta_1} \\ \beta_1 = \sin^{-1} \left(\frac{b \sin \delta_1}{p_1} \right) \end{cases}$$

$$F_{Tact} = \frac{M_T g L_{HG_T} \sin \theta_1 + M_S g [L_{HK} \sin \theta_1 + L_{KG_S} \sin(\theta_1 - \theta_2)]}{a \sin \beta_1}$$

Implementation details – PC104 / Athena board

Athena is an embedded CPU board from Diamond Systems.

Athena Board characteristic:

- form factor: 4.2" x 4.5"
- Pentium-III class VIA Eden Processor running at 400MHz
- On-board 128MB RAM
- 4 USB ports
- 16 single-ended /8 differential analog inputs, 16-bit resolution
- 4 analog outputs, 12-bit resolution
- 24 programmable digital I/O

Athena is compatible with the following operating systems: DOS, Linux, RTLinuxPro, QNX, Window 98/NT/XP/2000, Windows CE.Net, VxWorks

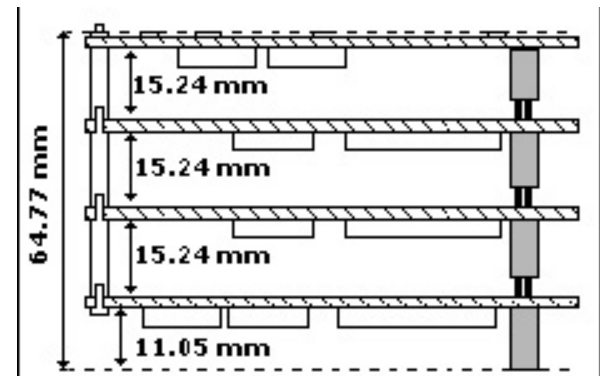

Implementation details – Windows CE .NET

- ❑ Windows CE.NET is a componentized operating system available to developers and device manufacturers to create customized embedded devices.
 - ❑ Windows CE has around 500 components. Minimum build size is approximately 200KB.
 - ❑ Windows CE.NET supports Microsoft eMbedded Visual C++® and Microsoft Visual Studio.NET
 - ❑ Windows CE.NET includes emulation technology that enables developers to build and test their design with a software that mimics hardware rather than testing the platform on hardware.
-

System evaluation – Path repeatability

- According to ISO 9283: **Path repeatability** expresses the closeness of the agreement between the attained paths for the same command path followed **n times in the same direction.**

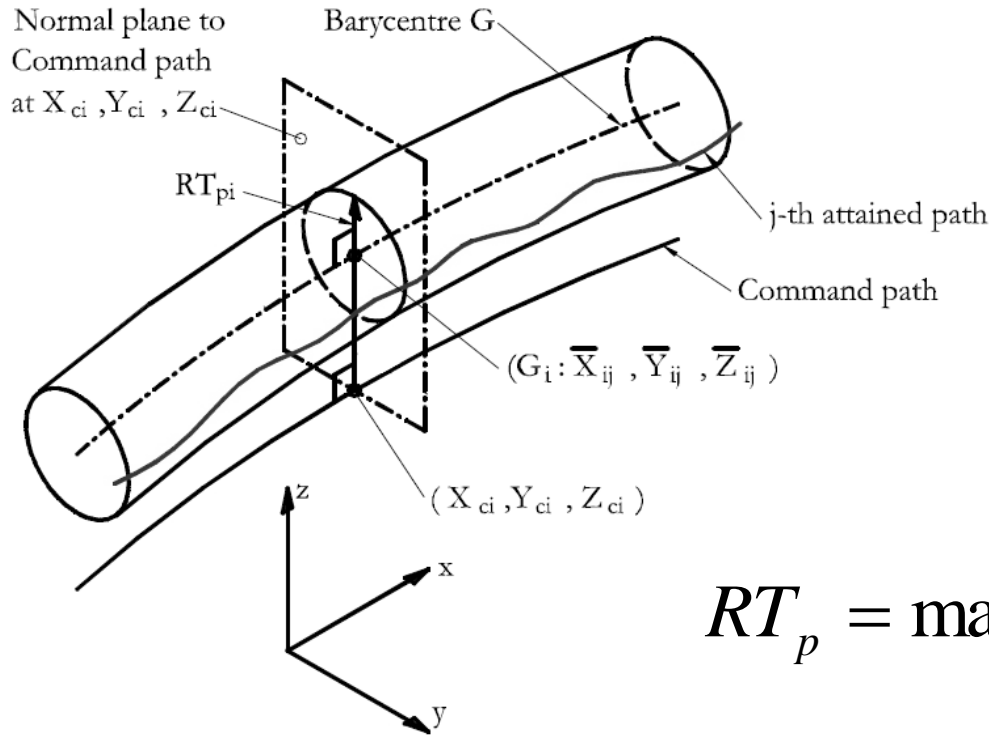

$$RT_p = \max RT_{pi} = \max[\bar{l}_i + 3S_{li}]$$

G - barycentre of a cluster of attained poses;

X_{ci} , Y_{ci} and Z_{ci} - coordinates of the i -th point of the command path;

X_{ij} , Y_{ij} and Z_{ij} - coordinates of the intersection j -th attained path and the i -th normal plane

System evaluation – Path repeatability

- Repeatability is defined as:

$$RT_p = \max RT_{pi} = \max[\bar{l}_i + 3S_{li}]$$

$$i = 1..m$$

m - number of calculated points along the path

$$\bar{l}_i = \frac{1}{n} \sum_{j=1}^n l_{ij} \quad S_{li} = \sqrt{\frac{\sum_{j=1}^n (l_{ij} - \bar{l}_i)^2}{n-1}}$$

$$l_{ij} = \sqrt{(x_{ij} - \bar{x}_i)^2 + (y_{ij} - \bar{y}_i)^2 + (z_{ij} - \bar{z}_i)^2}$$

- n - number of measurement cycles

$$\bar{x}_i = \frac{1}{n} \sum_{j=1}^n x_{ij} \quad \bar{y}_i = \frac{1}{n} \sum_{j=1}^n y_{ij} \quad \bar{z}_i = \frac{1}{n} \sum_{j=1}^n z_{ij}$$

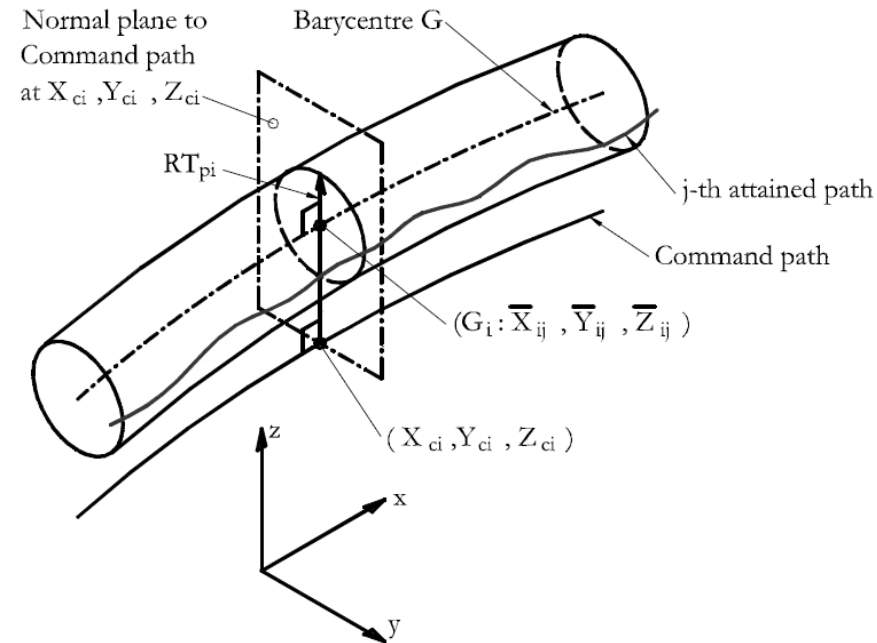

System evaluation – Path repeatability

□ Repeatability test results:

Test number	Repeatability (cm)
1	1.944
2	1.852
3	1.428
4	1.605
5	1.024
6	1.393
7	1.347
8	1.101
9	1.063
10	1.061

System evaluation – Path accuracy

- Maximum difference between target and experimentally obtained trajectory at ankle level is **1.2cm**

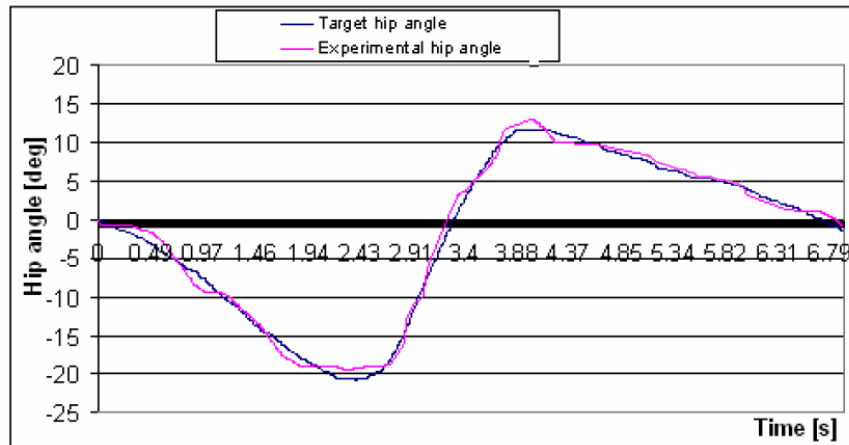

Comparison of target and experimentally obtained hip angle as function of time

Comparison of target and experimentally obtained knee angle as function of time

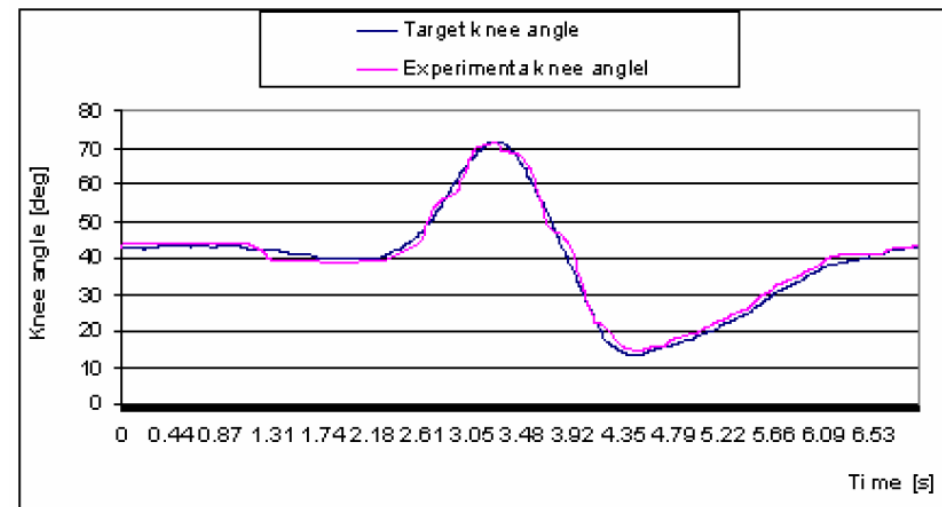

Q & A ?

Thank you for your attention!
